

1.11 DFQ/DFS MANIFOLD: ASSEMBLY

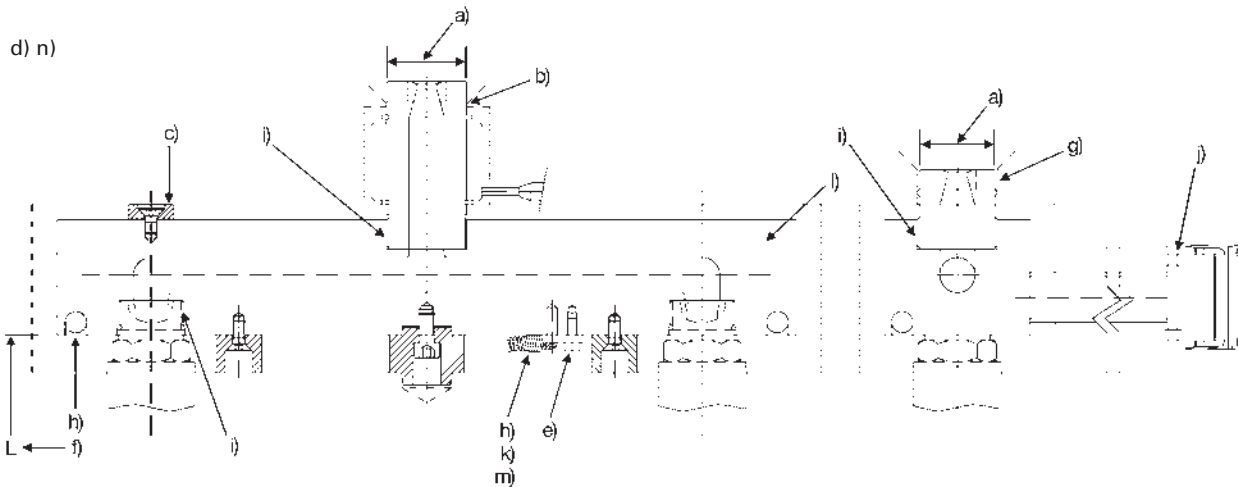

NOTES

- a) Must locate and seal.
- b) Contact max. 0.6 mm.
- c) Clearance for expansion to system drawing.
- d) Use anti-size for all threads.
- e) Tighten.
- f) Mold dimension must include expansion.
- g) For PP, PE, PS only.
- h) Protect all wires from heat.
- i) Consult INCOE® before removing.
- j) Wired and checked to customer specification.
- k) Fe-CuNi white = + / red = -
- l) If needed, before assembly to mold, heat up manifold to approx. 100°C (212°F).
- m) Extend TC only with Fe-CuNi wire.
- n) Before assembly check all zones individually at approx. 100°C (212°F).

PLEASE NOTE!

Refer to system drawing for assembly. Should you have any questions please contact our Applications or Service Department.